

Proportional pressure and flow control type QVHMZO, QVKMZOR

independent pressure and 3-way compensated flow regulation, ISO 4401 size 06 and 10

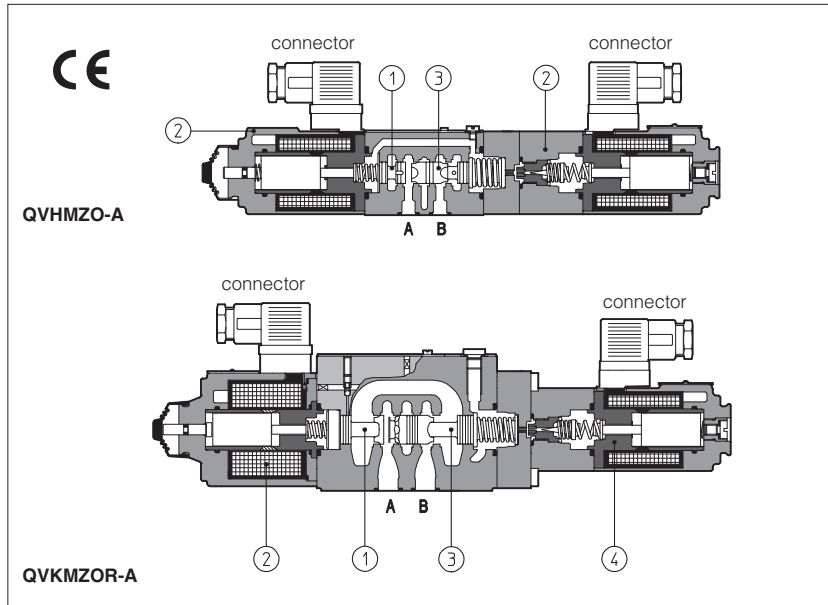

QVHMZO and QVKMZOR are proportional valves, direct operated, which provide independent pressure and 3-way compensated flow controls according to the electronic reference signals.

They operate in association with electronic drivers, see section 8 which supply the proportional valves with correct current signal to align valve regulation to the reference signal supplied to the electronic driver.

The flow is controlled by a throttle ①, directly operated by the proportional solenoid ②. The mechanical pressure compensator ③ keeps a constant Δp across the throttle ①, thus the regulated flow is independent to the load conditions.

The exceeding flow is returned to tank through the port P.

The pressure is controlled by the compensator ③, piloted by the proportional pressure relief valve ④.

The coils are fully plastic encapsulated (insulation class H) and valves have anti-vibration, antishock and weather-proof features.

Surface mounting: **ISO 4401, size 06 and 10.**
Max flow respectively up to **45 l/min** and **90 l/min**

Max pressure = **210 bar**

1 MODEL CODE

QVKMZOR - **A** - **10** / **65** / **210** / *

Pressure compensated flow control valves
QVHMZO = size 06
QVKMZOR = size 10

A = without position transducer

Valve size, see section 2

06 = ISO 4401, size 06

10 = ISO 4401, size 10

Max regulated flow: for **QVHMZO**:
30 = 35 l/min
40 = 45 l/min

for **QVKMZOR**:
65 = 65 l/min
90 = 90 l/min

**	/	*
Seals material		
- = NBR		
PE = FKM		
Series number		

Coil voltage (only for -A execution)

- = standard coil for 24V_{DC} Atos drivers

6 = optional coil for 12V_{DC} Atos drivers

18 = optional coil for low current drivers

max pressure:
210 = 210 bar

2 HYDRAULIC CHARACTERISTICS (based on mineral oil ISO VG 46 at 50 °C)

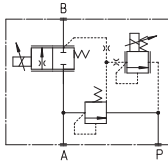
Hydraulic symbols				
Note: Port T must always be plugged.				
Valve model	QVHMZO-A-06		QVKMZOR-A-10	
Max regulated flow [l/min]	35	45	65	90
Min regulated flow [cm ³ /min]	50	60	85	100
Regulating Δp [bar]	10-12	15	6 - 8	10 - 12
Max flow on port A [l/min]	50	55	70	100
Max regulating pressure [bar]	210			
Response time 0÷100% step signal (1) [ms]	30		45	
Hysteresis [% of the regulated max flow]	≤ 5		≤ 5	
Linearity [% of the regulated max flow]	≤ 3		≤ 3	
Repeatability [% of the regulated max flow]	≤ 1		≤ 1	

Above performance data refer to valves coupled with Atos electronic drivers, see sections 8.

(1) Response times at step signal (0%→100%) are measured from 10% to 90% of step value and are strictly referred to the valve regulation.

3 MAIN CHARACTERISTICS OF PROPORTIONAL PRESSURE AND FLOW VALVES TYPE QVHMZO-A AND QVKMZOR-A

Assembly position	Any position
Subplate surface finishing	Roughness index Ra 0,4 - flatness ratio 0,01/100 (ISO 1101)
Ambient temperature	-20°C ÷ +70°C for -A execution
Fluid	Hydraulic oil as per DIN 51524 ... 535 for other fluids see section I
Recommended viscosity	15 ÷ 100 mm ² /s at 40°C (ISO VG 15÷100)
Fluid contamination class	ISO 4406 class 20/18/15 NAS 1638 class 9, in line filters of 10 µm (β ₁₀ ≥ 75 recommended)
Fluid temperature	-20°C +60°C (standard seals) -20°C +80°C (/PE seals)

3.1 Coils characteristics

Valve model		QVHMZO-A			QVKMZOR-A		
		Standard	option /6	option /18	Standard	option /6	option /18
Coil resistance R at 20°C	pressure	3 ÷ 3,3 Ω	2 ÷ 2,2 Ω	13 ÷ 13,4 Ω	3 ÷ 3,3 Ω	2 ÷ 2,2 Ω	13 ÷ 13,4 Ω
Max. solenoid current	pressure	2,6 A	3,25 A	1,5 A	2,6 A	3,25 A	1,5 A
Coil resistance R at 20°C	flow	3 ÷ 3,3 Ω	2 ÷ 2,2 Ω	13 ÷ 13,4 Ω	3,8 ÷ 4,1 Ω	2,2 ÷ 2,4 Ω	12 ÷ 12,5 Ω
Max. solenoid current	flow	2,2 A	2,75 A	1,2 A	2,6 A	3,25 A	1,2 A
Max. power		30 Watt			35 Watt		
Protection degree (CEI EN-60529)		IP65					
Duty factor		Continuous rating (ED=100%)					

4 ELECTRIC WIRING

Electric wiring to reference generators must be made using shielded cables: the sheat must be connected to the power supply zero **on the generator side**. The power supply must be properly stabilized or rectified and filtered. For complete electric wiring with all available options, see section G

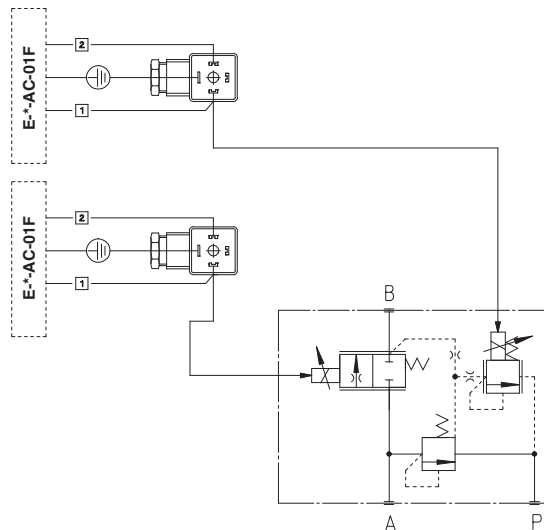

PIN	Connector
1	COIL LEAD
2	COIL LEAD
⊕	EARTH CONDUCTOR

Note:

In case the A inlet flow is < 18 l/min for QVHMZO and < 25 l/min for QVKMZOR, a check valve with cracking pressure 2 bar is suggested in P port to improve the valve stability.

Note: basic information for commissioning and start-up are present on installation notes always enclosed to the specific technical tables and relevant components.

5 TYPICAL APPLICATION SKETCH

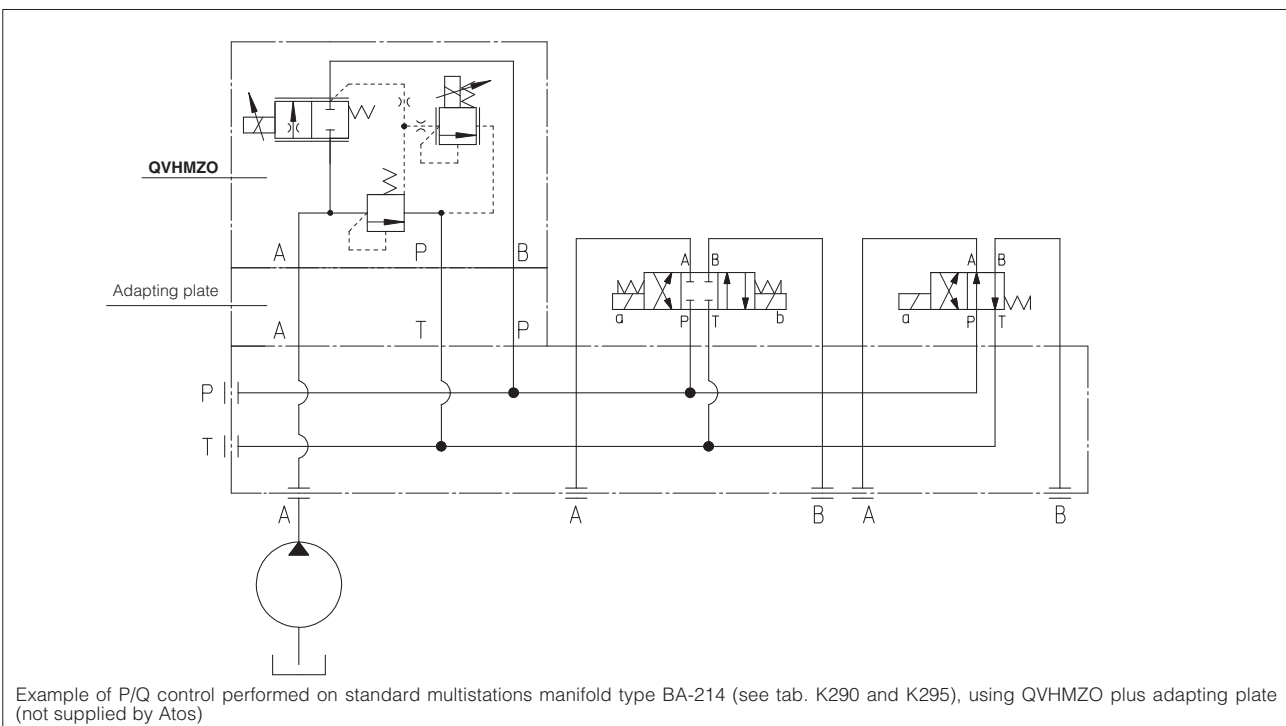

6 DIAGRAMS (based on mineral oil ISO VG 46 at 50 °C)

6.1 Flow regulation diagrams

- 1 = QVHMZO-A-06/30
- 2 = QVHMZO-A-06/40
- 3 = QVKMZOR-A-10/65
- 4 = QVKMZOR-A-10/90

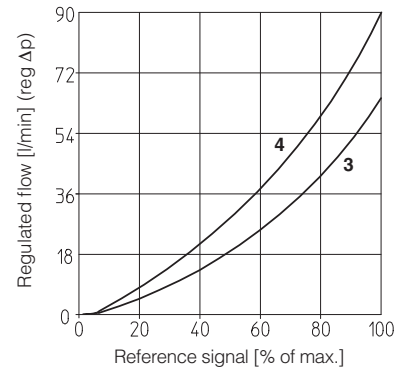
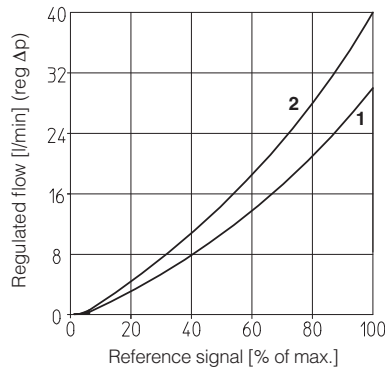

6.2 Pressure regulation diagrams

- 1 = QVHMZO-A-06/30
- 2 = QVHMZO-A-06/40
- 3 = QVKMZOR-A-10/65
- 4 = QVKMZOR-A-10/90

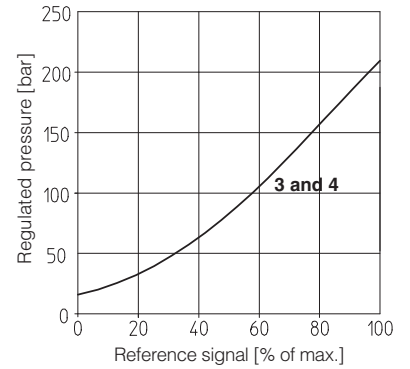
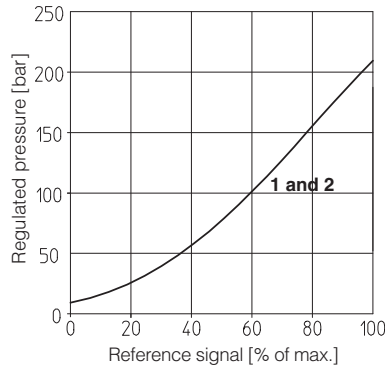

6.3 Regulated flow/outlet pressure diagrams
with inlet pressure = 210 bar

- 1 = QVHMZO-A
- 2 = QVKMZOR-A

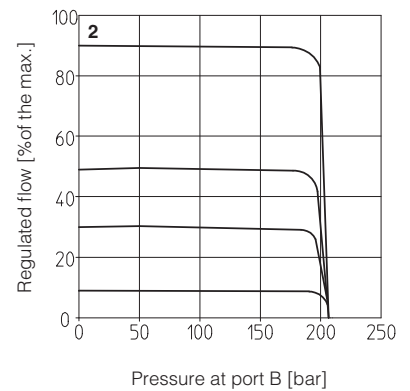
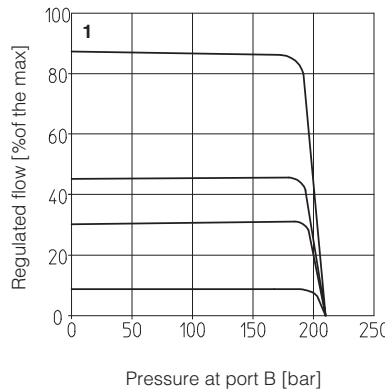

6.4 Flow A→P/Δp diagrams
3-way configuration

- 1 = QVHMZO-A-06/30
- 2 = QVHMZO-A-06/40
- 3 = QVKMZOR-A-10/65
- 4 = QVKMZOR-A-10/90

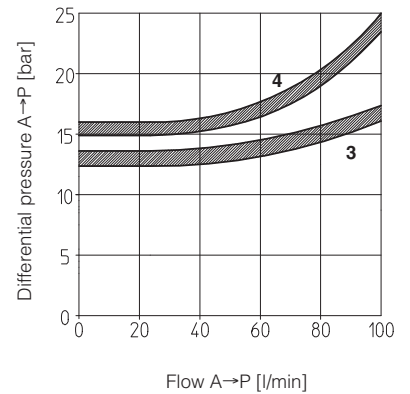
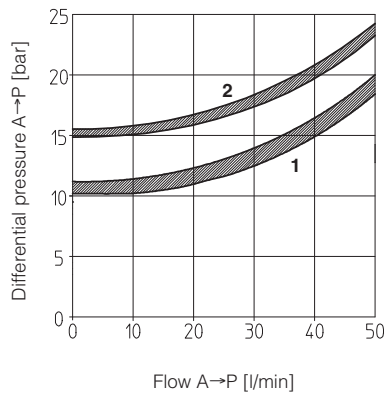

7 INSTALLATION DIMENSIONS [mm]

QVHMZO

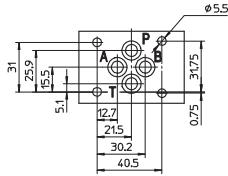

ISO 4401: 2005
Mounting surface: 4401-03-02-0-05
 Fastening bolts:
 4 socket head screws M5x50 class 12.9
 Tightening torque = 8 Nm
 Seals: 4 OR 108;
 Diameter of ports A, B, P, T:
 Ø 7,5 mm (max)

A = INLET PORT
B = OUTLET PORT
P = DISCHARGE PORT
T = NOT USED
 (it must be plugged)

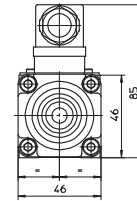
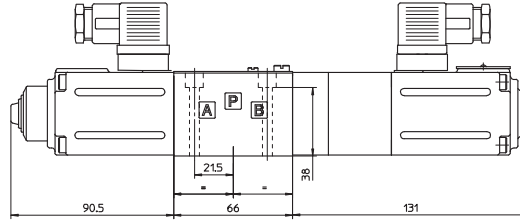

Mass: 2,8 kg

QVKMZOR

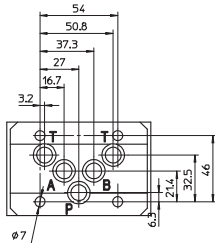

ISO 4401: 2005
Mounting surface: 4401-05-04-0-05
 Fastening bolts:
 4 socket head screws M6x40 class 12.9
 Tightening torque = 15 Nm
 Seals: 5 OR 2050;
 Diameter of ports A, B, P, T: Ø 11,2 mm (max)

A = INLET PORT
B = OUTLET PORT
P = DISCHARGE PORT
T = NOT USED
 (it must be plugged)

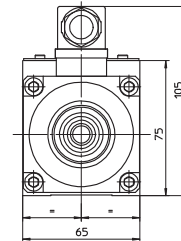
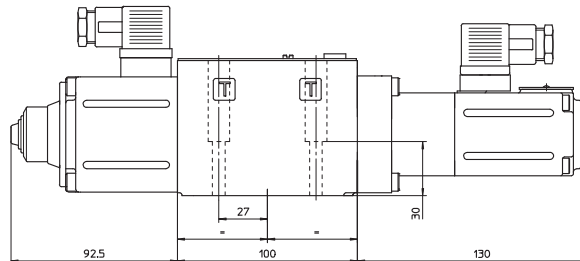

Mass: 4,3 kg

8 ELECTRONIC DRIVERS FOR QVHMZO-A AND QVKMZOR-A

Valve model	-A					
Drivers model	E-MI-AC-01F	E-MI-AS-IR	E-BM-AC-011F	E-BM-AS	E-ME-AC-01F	E-RP-AC-01F
Data sheet	G010	G020	G025	G030	G035	G100

For complete information about the drivers characteristics and relevant options, see the technical data sheet specified in the table.

9 MOUNTING PLATES

Size	Model	Ports location	Gas ports A, B, P, T	Ø Counterbore A, B, P, T	Mass [kg]
06	BA-202	Ports A, B, P, T underneath;	3/8"	-	1,2
	BA-204	Ports P, T underneath; ports A, B on lateral side	3/8"	25,5	1,8
	BA-302	Ports A, B, P, T (X, Y) underneath;	1/2" (1/8")	30 (16,5)	1,8
10	BA-308	Ports A, B, P, T underneath;	1/2"	30	2,5
	BA-428	Ports A, B, P, T underneath;	3/4"	36,5	5,5
	BA-434 (Y)	Ports P, T (X, Y) underneath; A, B on lateral side	3/4" (1/4")	36,5 (21,5)	8,5